

1. Introduction

This document is intended for everybody who wishes to use or investigate the Henry Audio USB DAC 128 mkII and its predecessors (Henry Audio USB DAC 128, QNKTC AB-1.2, AB-1.1 and AB-1.0). The schematics for all these products are Open Source!

Programmers and developers should also read the complete project readme file at https://github.com/amontefusco/sdr-widget/blob/audio-widget-experimental/AW_readme.txt

For commercial reuse of the technology behind Henry Audio's products you should contact borge@henryaudio.com

The contents of this file are:

1.	Introduction	1
2.	Technical Specifications	1
3.	USB Audio Class 1 & 2.....	2
4.	Asynchronous USB Audio	3
5.	Disabling resampling	3
6.	Installation on Windows.....	5
7.	Setup with JRiver Media Center	5
8.	Setup with foobar2000	6
9.	Windows Uninstall Procedure.....	8
10.	Schematic Files	10

2. Technical Specifications

The USB DAC 128 mkII plugs in between your computer and an audio amplifier. It will work on Linux, Mac and Windows. With a powered USB hub and an on-the-go cable it will also work on Android and iOS devices. High resolution audio is not guaranteed on Windows XP.

The electrical design focuses on high quality circuit board layout and good components.

Some technical details:

- A fully assembled, tested and packaged DAC which plays music out of the box
- Asynchronous USB Audio powered by Golledge high-quality crystal oscillators at 22.5792 and 24.576MHz
- Supports the common sample rates of 44.1, 48, 88.2, 96, 176.4 and 192ksps
- RCA (phono) stereo outputs

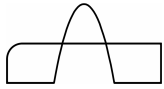

Henry Audio

- Asahi Kasei AKM4430 DAC
- Atmel AVR32 general-purpose MCU programmed in open source C
- ASIO driver for Windows programmed in open source C
- Low-noise 3.3V ADP151 LDOs powered from USB. No external power supply.
- The option of experimenting with the power supply.
- Lots of internal headers for experimenting.
- You must provide a USB 2.0 mini-B cable. It is not included. Use a cable shorter than 3m.
- Mechanical size: W: 114.4mm, H: 32.8mm, D: 128mm.
- Computer requirement: The DAC will work on well on all modern computers. The DAC may not work well on computers with processors below the performance of a Core 2-duo / 2GHz CPU. USB Audio Class 2 drivers may not work on Windows XP.

3. USB Audio Class 1 & 2

USB Audio has two different ways to work, USB Audio Class 1 and 2. The USB DAC 128 mkII will operate in both UAC1 and UAC2.

The reason for supporting two modes is that only UAC1 is supported natively in Windows while UAC2 is needed for high resolution playback. When the DAC is first powered on it will use UAC1. That way it will work right out of the box on all computers, and the playback will have more than CD quality.

OS X, Linux, iOS and Android support both UAC1 and UAC2 natively. On those systems you may as well select UAC2 as you start using your new DAC.

For hi-res playback on Windows an ASIO driver is provided. This enables hi-res in select media player programs. Installation and setup details are given below.

UAC1 is more than enough if the music you play was once on a CD. The Henry Audio USB DAC 128 mkII supports up to 24 bit / 48ksps in UAC1. That is more than sufficient for ripped CDs or streaming.

UAC1 is indicated by a green light at the front of the USB DAC 128 mkII. UAC2 is indicated by a red light. To switch between the two modes do as follows:

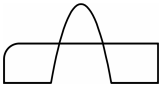

Henry Audio

- Press the rear Prog button until the light changes
- Keep pressing Prog until the light goes dark
- Press and release Reset

4. Asynchronous USB Audio

The USB audio protocol is *asynchronous* with both UAC1 and UAC2. That means the analog part of the DAC minimizes jitter errors.

What does *asynchronous USB* mean? It means the DAC is the timing master. In typical digital audio based on S/PDIF (coax) and TOSLINK (optical) cables the audio data and the clock are synchronous. Both travel from the same source. This source is typically a CD drive. Such a drive may or may not be made with a good internal clock circuit.

Synchronous digital audio is also common over USB. Then the timing reference is derived inside the computer. That clock is often very noisy. With synchronous digital audio the DAC is responsible for extracting the clock signal.

Instead, with an asynchronous protocol, the source of the audio data becomes the timing slave. Commands are sent on the USB cable from the DAC to tell the computer to speed up or slow down. This enables the DAC to use precision crystal oscillators instead of a complex clock regenerator. The audible result is that many of the typically digital artifacts are significantly reduced.

5. Disabling resampling

Most modern operating systems, with the exception of iOS, will automatically resample your digital music as it is being played back. This is not a major issue but it may improve sound quality to turn it off. Some player programs disable resampling on their own. On Windows using the protocols WASAPI or ASIO disables resampling.

Because most digital music is recorded at the CD's sample rate of 44.1ksps, you are recommended to set this as the default sample rate for the DAC.

Linux and MPD

If you use Linux and MPD make sure you enter the following line in the `audio_output` section of your `.mpdconf` file:

```
auto_resample "no"
```

This will disable resampling, and you don't need to set a default rate.

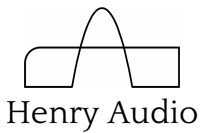

OS X

In OS X the sample rate setting for a DAC is set in the "Audio MIDI Setup". Look for this icon under Applications, Utilities:



The 44.1ksp/s setting is the best way to use generic Mac programs to play back music which was once stored on a CD. It is also the recommended setting for streaming music from the internet.

For playback of hi-res material, make sure that your player program is able to override the sample rate setting of OS X.

NB: On your Mac you should set the default sample rate to 44.1ksp/s for both UAC1 and UAC2 configurations of the DAC. That is because your computer will recognize those as two different DACs.

Windows

On Windows you can only set the default sample rate to 44.1ksp/s when the DAC is in UAC1 mode. In UAC2 mode, with the ASIO driver, there is no need to do this. Follow these steps to set the sample rate:

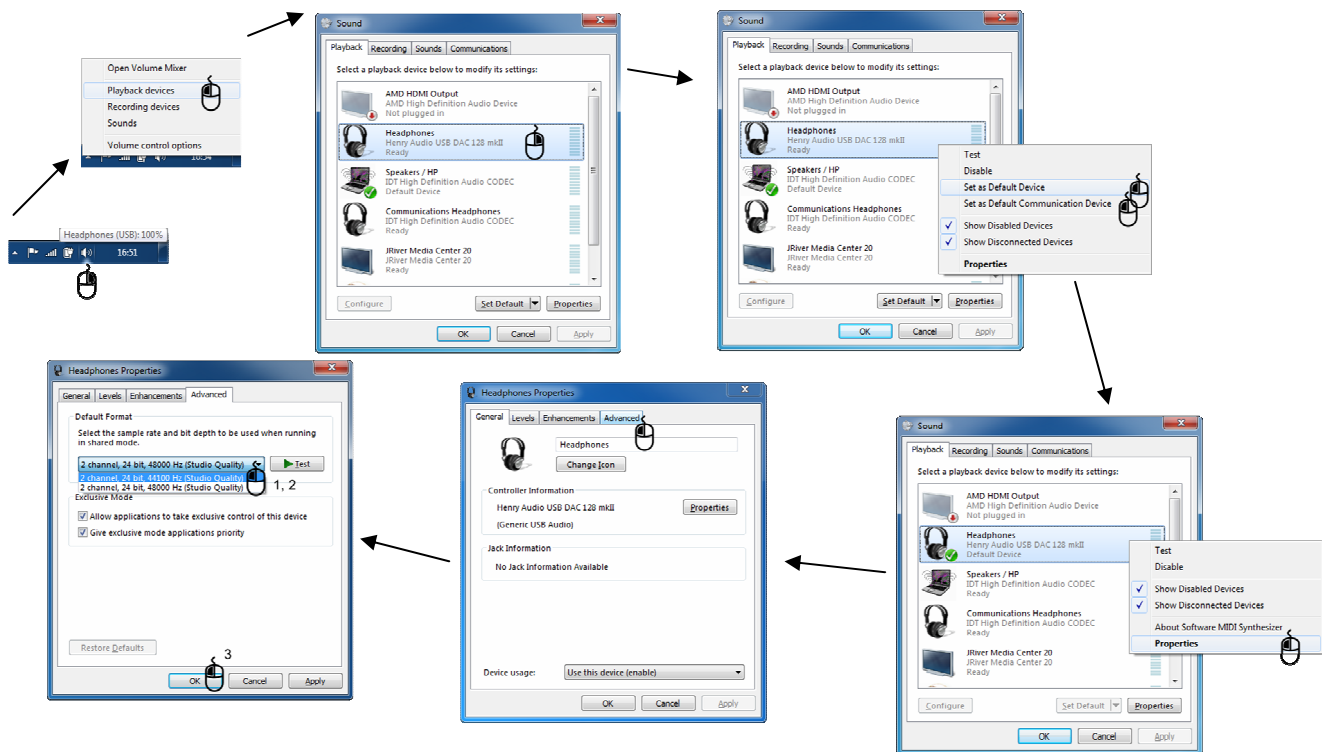

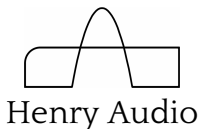

6. Installation on Windows

Windows does not come with built-in support for USB Audio Class 2. The Henry Audio USB DAC 128 mkII is shipped with the supported UAC1 mode to work with any Windows program using built-in drivers.

This means all Windows programs can play back music in CD quality (actually up to 24 bit / 48ksps) using UAC1. If this suits your needs you do *not* have to install any special Windows drivers.

If you want to listen to high-resolution music on a Windows computer you will need to install the ASIO driver and use high quality media player programs. This manual will explain how to play back hi-res files in two Windows programs, JRiver Media Center and foobar2000.

When the DAC is in UAC2 mode it will not be recognized by Windows as an audio device. This has the added benefit that sounds like "Pling, you got mail" will not be mixed in with music you play back through the ASIO driver.

Follow these steps to install the hi-res ASIO driver for the USB DAC 128 mkII on a Windows 7 / 8 / 10 computer. Windows XP functionality is not guaranteed.

1. Do not plug in the USB DAC 128 mkII yet.
2. If you have an earlier version of the driver installed, first follow the uninstall instructions later in this text.
3. Download and install the driver from https://github.com/borgstrand/widget_binaries/blob/master/AWSetup_20130211.zip
4. Answer Yes and OK to all questions. You may have to approve that an unsigned driver may be installed.
5. Put the DAC into UAC2 mode according to section 3. The first time you change modes, Windows may have to install additional drivers. It should be able to do that fully automatically.

7. Setup with JRiver Media Center

The JRiver Media Center is a powerful media playback program. It offers a 30-day free use and after that must be paid for. The license cost is currently USD 50.

After following the steps on driver installation do as follows:

1. Download and install Media Center from <http://www.jriver.com/download.html>
2. Plug in the USB DAC 128 *mkII*
3. Given 5 minutes or less, Windows should be able to find and install all drivers



Henry Audio

J-River Media Center is set up to use the default sound output device. Here is how to set it up to use the USB DAC 128 mkII with UAC2 and ASIO. This will enable you to listen to hi-res music.

1. First do as above to select UAC2 and a red front LED color
2. Start J-River Media Center
3. Click the top-right bars icon:



4. In the Tools window choose Playback Options:

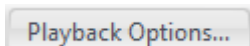

5. In the Options window choose ASIO:

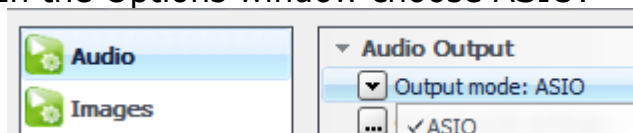

6. Click Output Mode Settings:

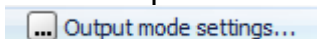

7. In the ASIO Settings window choose Device = ASIO UAC2:

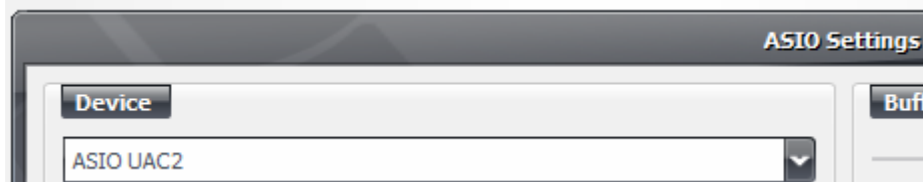

8. Click OK in all windows to close them
9. Use the file menu to open up your music files and play them

NB: ASIO drivers are shown on the pull-down menu even if the DAC served by the driver is not plugged in.

8. Setup with foobar2000

foobar2000 is a free music playback program for Windows. It has good ASIO integration and some strong features.

After following the steps on driver installation do as follows:

1. Download and install foobar2000 from <http://www.foobar2000.org/download>
2. Download and install the foobar2000 ASIO plug-in from http://www.foobar2000.org/components/view/foo_out_asio. The ASIO plug-in installation will reconfigure and restart foobar2000.

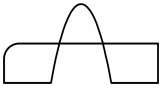

Henry Audio

3. Plug in the USB DAC 128 mkII
4. Given 5 minutes or less, Windows should be able to find and install all drivers

foobar2000 is set up to use the default sound output device. Here is how to set it up to use the USB DAC 128 mkII with UAC2 and ASIO. This will enable you to listen to hi-res music.

1. First do as above to select UAC2 and a red front LED color
2. Start foobar2000
3. Click "File" and then "Preferences"
4. Expand "Playback" and under it expand "Output".

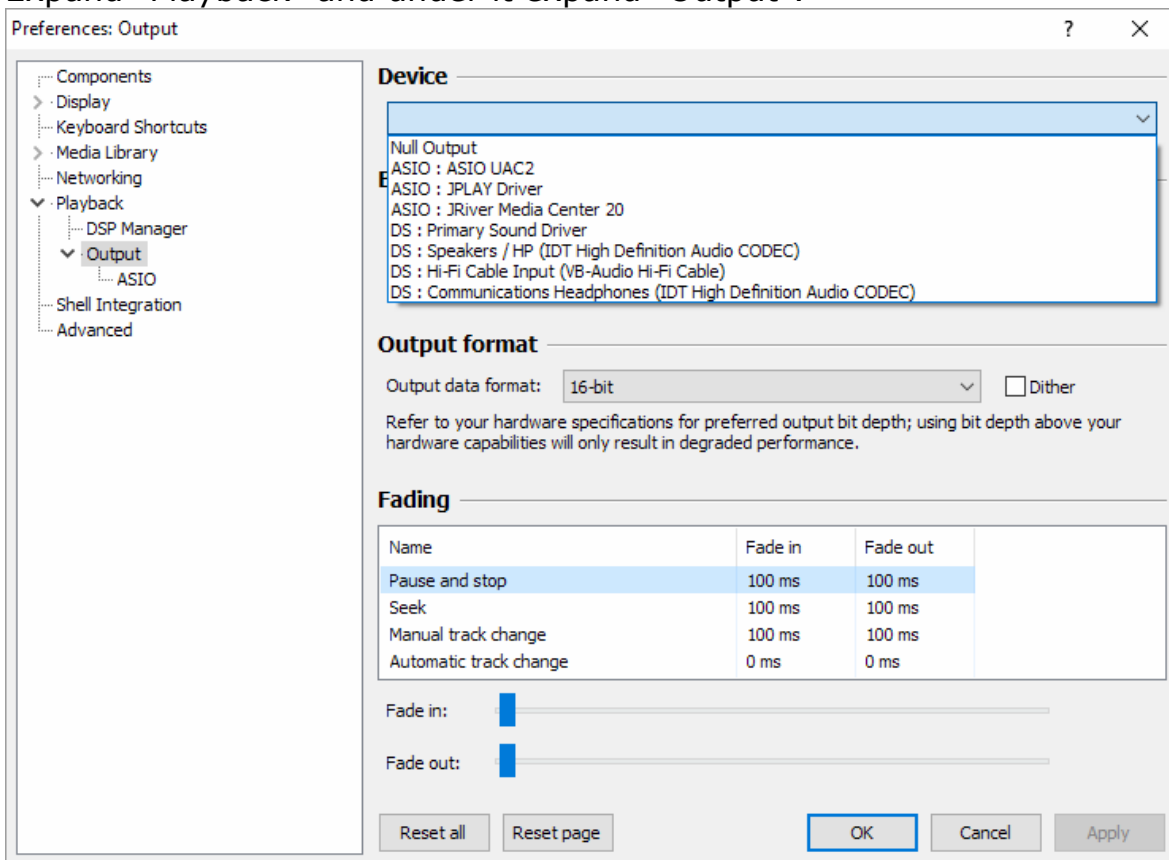

5. From the Device pull-down menu select "ASIO UAC2".
6. Under "Output" in the left-hand menu click "ASIO". Make sure that "Use 64-bit ASIO drivers" is *not* selected.
7. Click OK.
8. Your music should now come out of the Henry Audio USB DAC 128 mkII

NB: ASIO drivers are shown on the pull-down menu even if the DAC served by the driver is not plugged in.

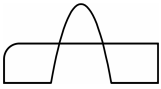

9. Windows Uninstall Procedure

This text applies if you have installed an UAC2 ASIO driver from before 2013-02-11 or if you need to reinstall the ASIO driver.

1. Unplug the USB DAC 128 mkII
2. Uninstall Audio-Widget in Start menu or C:\Program Files (x86)\Audio-Widget

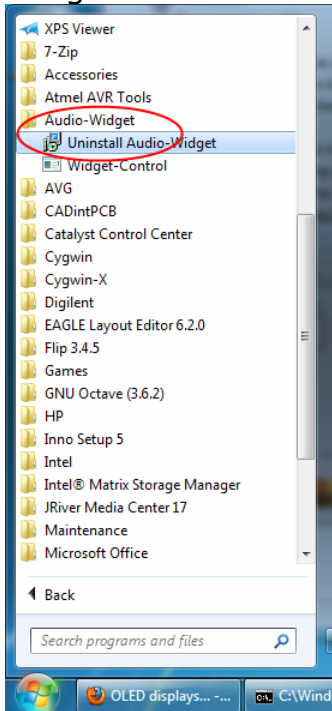

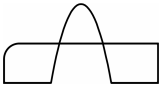

3. Open the Start menu and type in "cmd". On the icon on top, right-click and choose "Run as Administrator". Click "OK" in the User Account Control window.

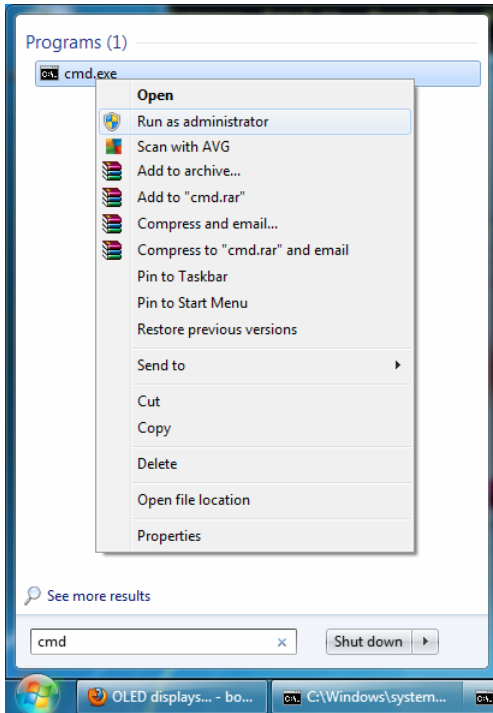

4. At the command prompt, type in "set devmgr_show_nonpresent_devices=1" and press Enter. See next picture.
5. On the next command prompt line, type "devmgmt.msc" and press Enter. This will launch the Windows Device Manager Console.

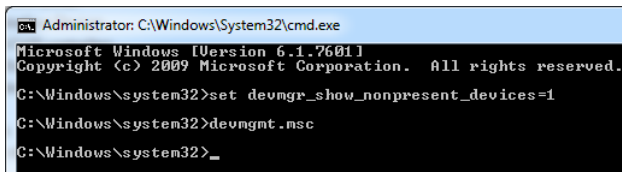

6. In the Device Manager Console, from the View menu, select "Show Hidden Devices".

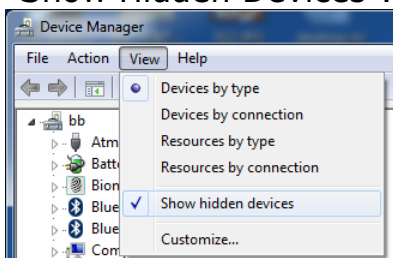

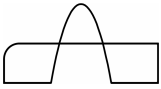

Henry Audio

7. Search under tabs for "libusbK USB Devices", "Sound, video...", "Audio-Widget...", "UAC2..."

Under all those tabs, delete and uninstall all drivers and anything resembling:

"Audio-Widget", "SDR-Widget", "DG8SAQ", "QNKTC", "Henry Audio", "Yoyodyne", "UAC2"

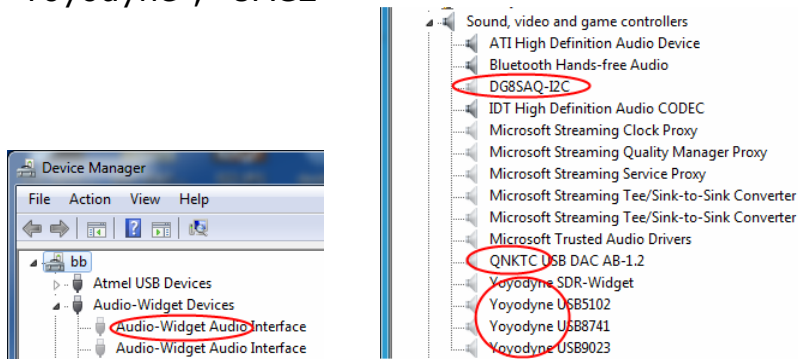

8. You should now be ready to install the new fresh version of the drivers as shown in the previous section.

10. Schematic Files

The schematics of the USB DAC 128 mkII are appended to this document. They are part of the open source Audio Widget project.

USB DAC 128 mkII schematics by [Henry Audio / Børge Strand-Bergesen](#) is licensed under a [Creative Commons Attribution-ShareAlike 4.0 International License](#).

Based on a work at http://www.henryaudio.com/uploads/fact_sheet_mkII.pdf and SDR Widget BETA 2.0 by George Boudreau.

ASIO is a trademark and software of Steinberg Media Technologies GmbH.



MCU_USB

IN_OUT

CLOCKS

POWER

DEBUG

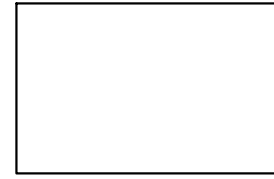
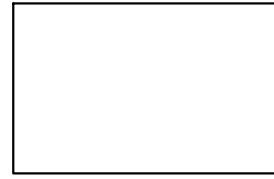
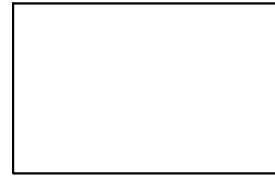
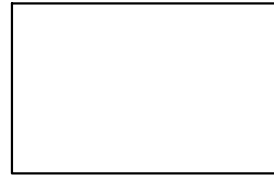
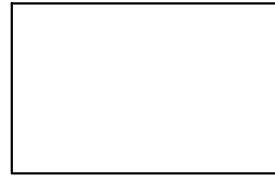

USB DAC 128 mkII schematics by Henry Audio / Børge Strand-Bergesen - borge@henryaudio.com
 is licensed under a Creative Commons Attribution-ShareAlike 4.0 International License.
 Based on a work at http://www.henryaudio.com/uploads/fact_sheet_mkII.pdf
 and SDR Widget BETA 2.0 by George Boudreau
 See <http://creativecommons.org/licenses/by-sa/4.0/>

Designed by BSB	Checked by BSB	Approved by - date BSB	Filename U128_2_M	Date 20141012	Scale 1:1
Drawing Number U128_2_M			Henry Audio Top		
				Edition H	Sheet 8 of 13



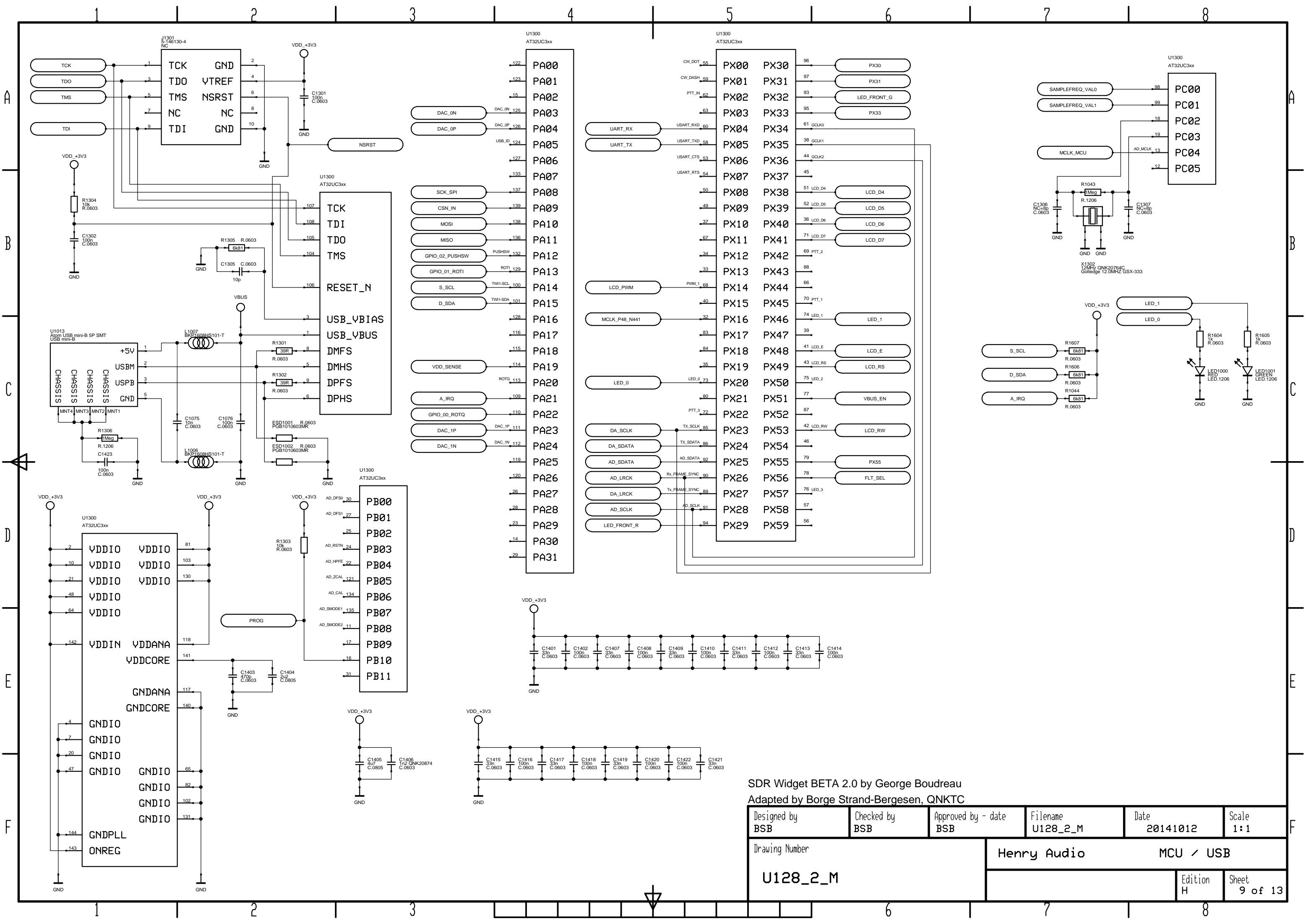

SDR Widget BETA 2.0 by George Boudreau
 Adapted by Borge Strand-Bergesen, QNKTC

Designed by BSB	Checked by BSB	Approved by - date BSB	Filename U128_2_M	Date 20141012	Scale 1:1
Drawing Number U128_2_M			Henry Audio MCU / USB		
				Edition H	Sheet 9 of 13

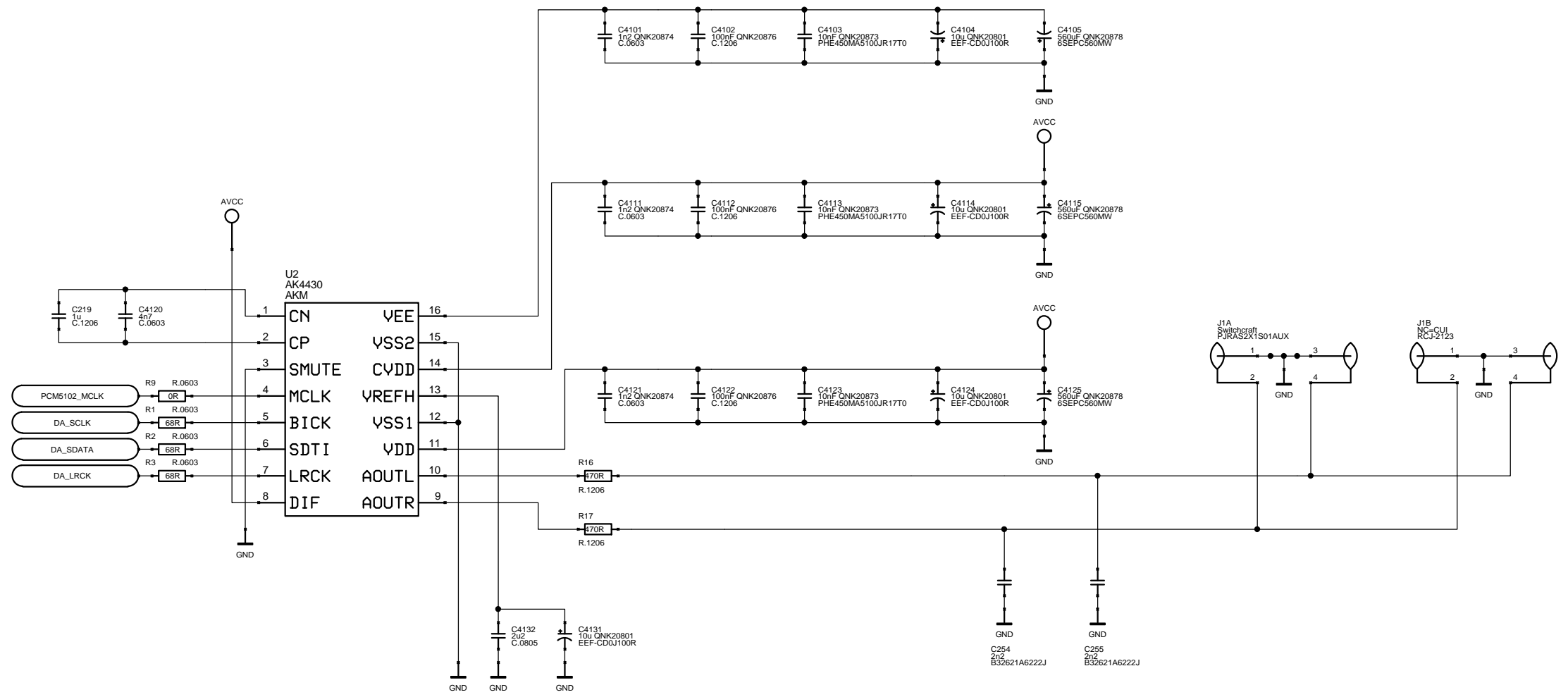
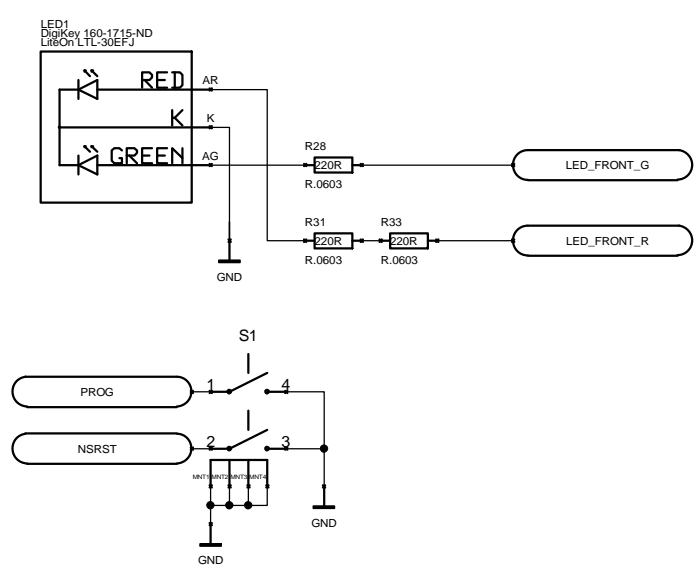

Designed by BSB	Checked by BSB	Approved by - date BSB	Filename U128_2_M	Date 20141012	Scale 1:1
Drawing Number U128_2_M			Henry Audio		In / Out
				Edition H	Sheet 10 of 13

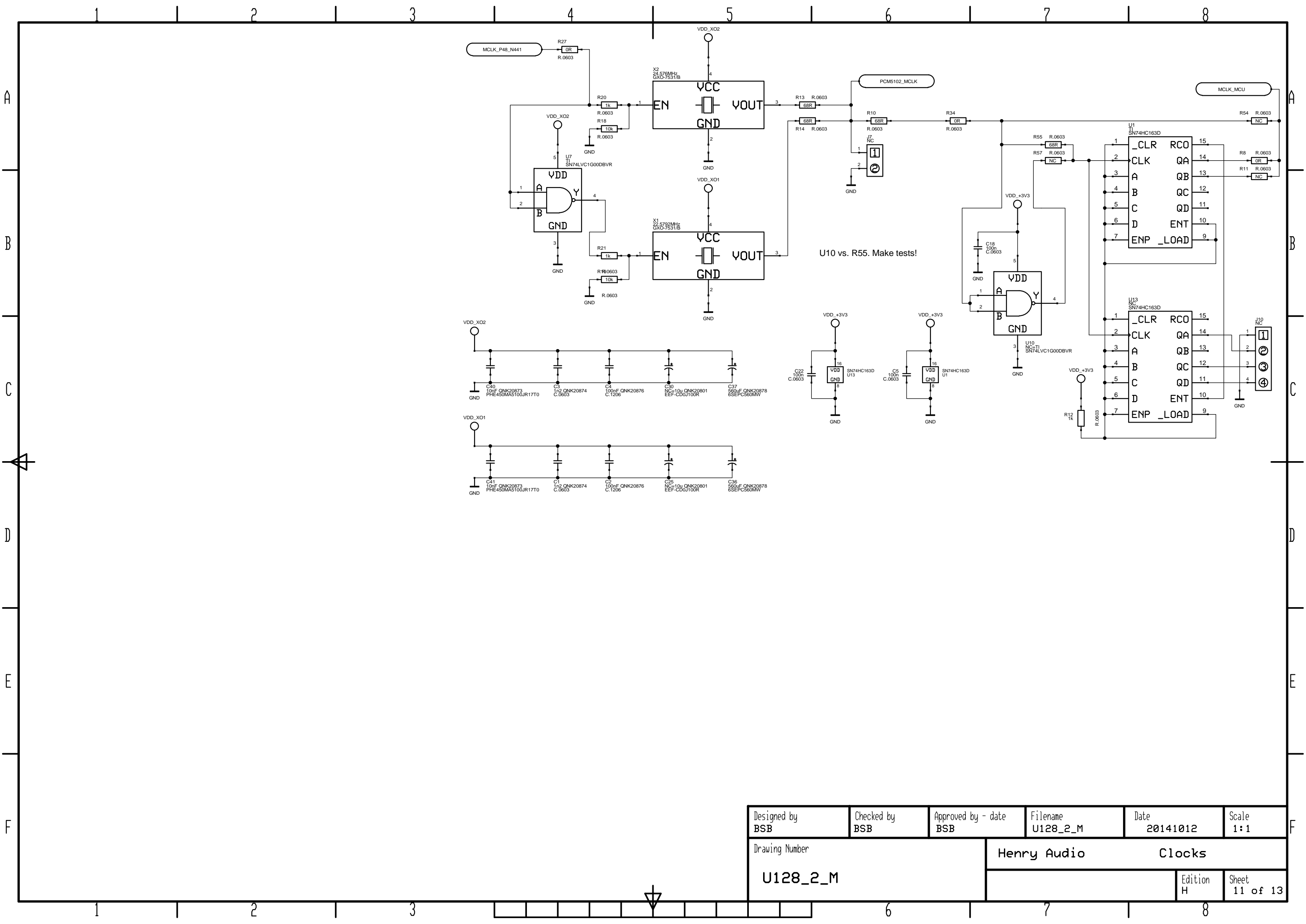

Designed by BSB	Checked by BSB	Approved by - date BSB	Filename U128_2_M	Date 20141012	Scale 1:1
Drawing Number U128_2_M			Henry Audio		Clocks
			Edition H		Sheet 11 of 13

Analog power DAC & clock

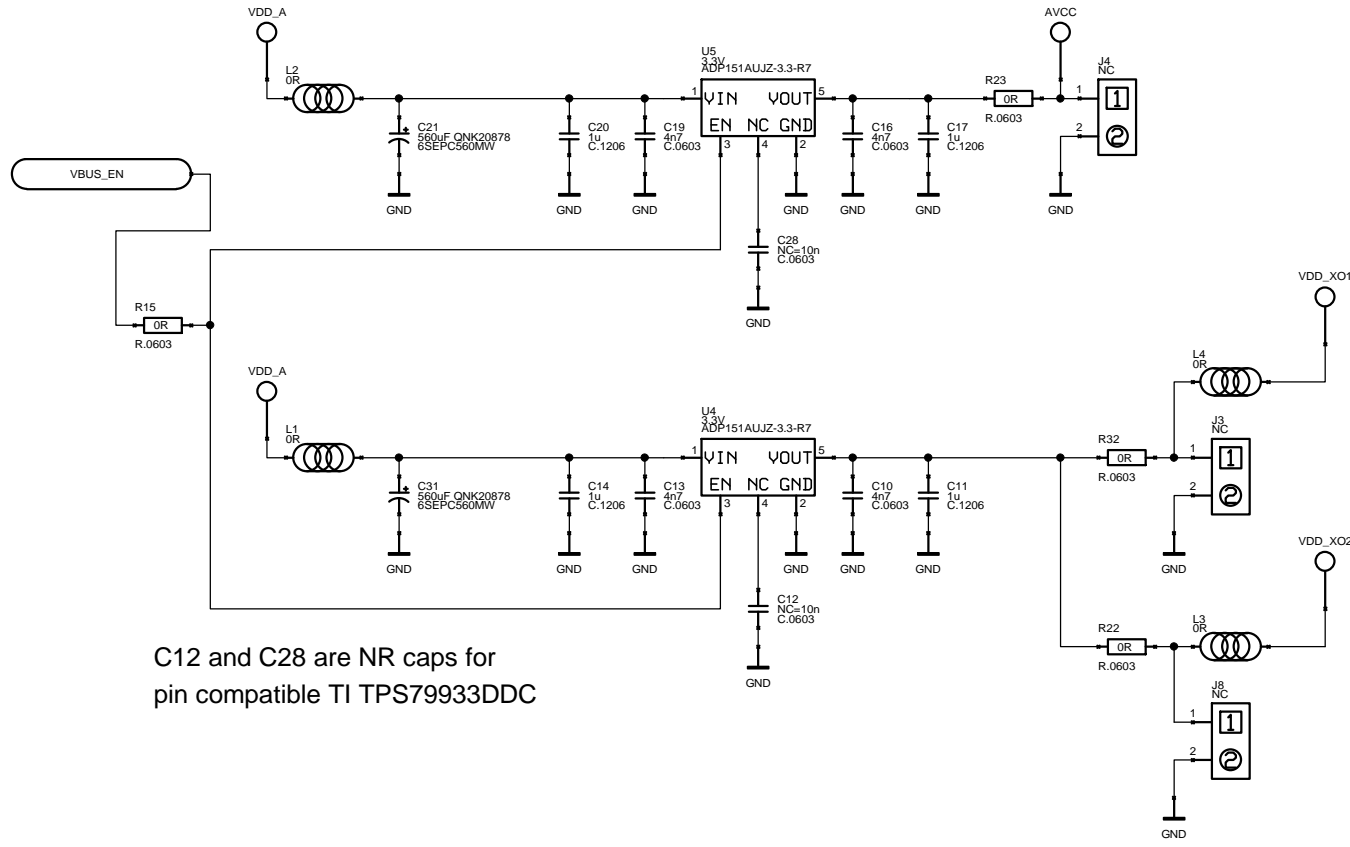

C12 and C28 are NR caps for pin compatible TI TPS7993DDC

MCU regulator

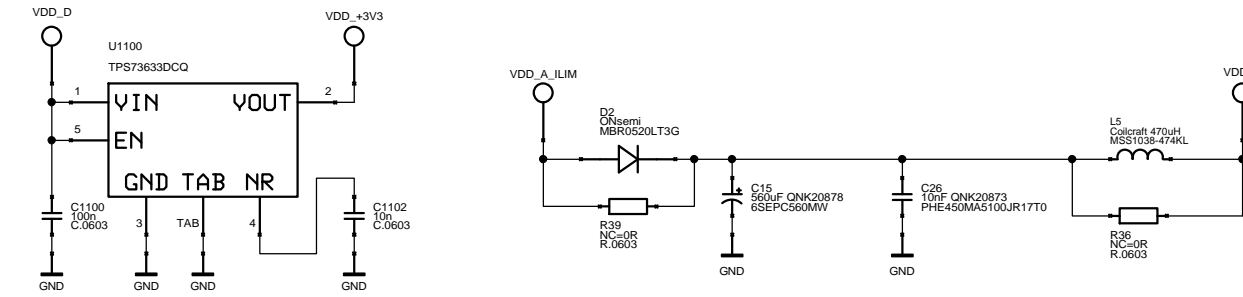

Unpopulated regulator by 1Audio

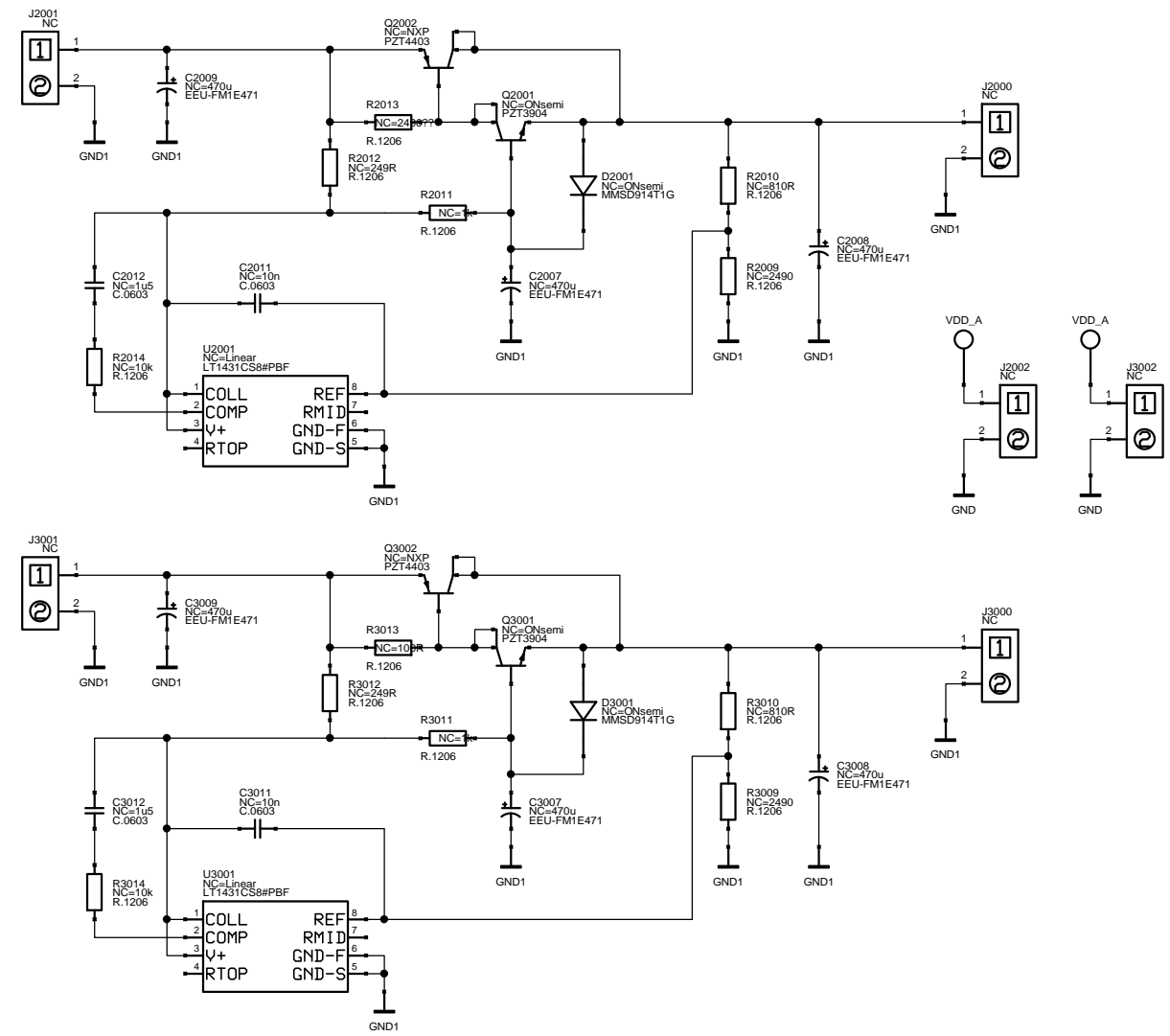

AB-1.x current inrush current limiter

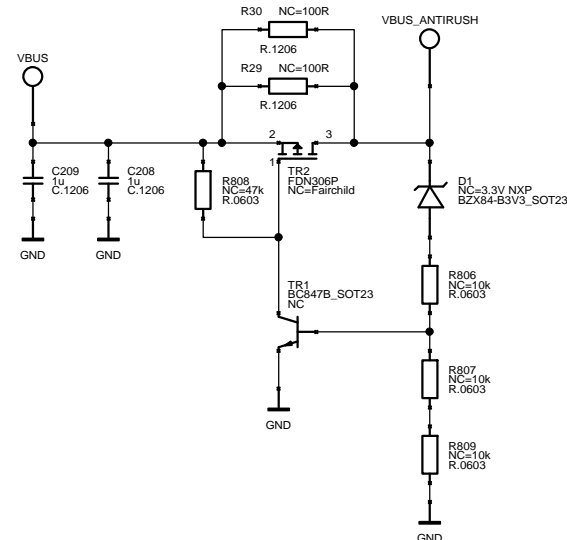

Power bypass breakout

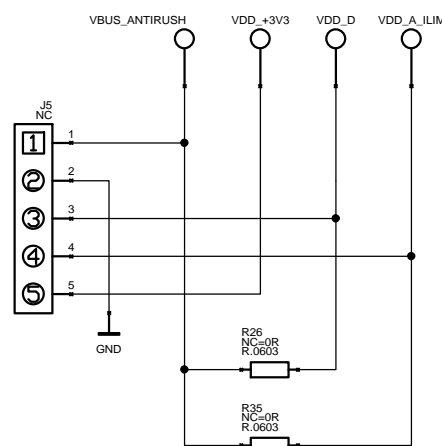

Alternative current limiting power switch

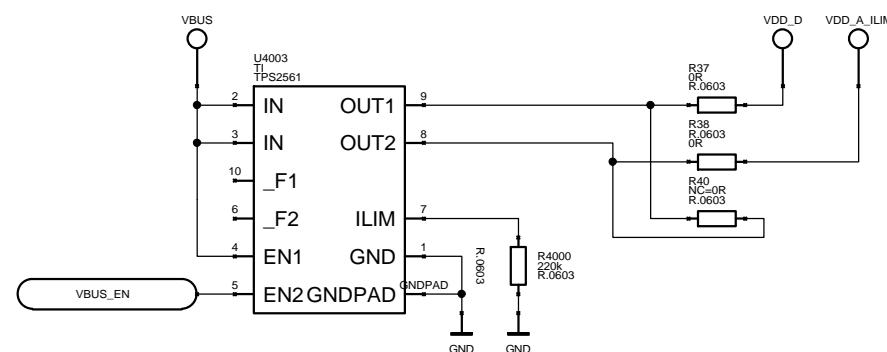

Monitor external power
Not enabled in software

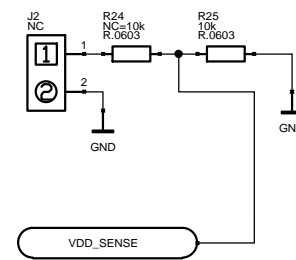

Designed by BSB	Checked by BSB	Approved by - date BSB	Filename U128_2_M	Date 20141012	Scale 1:1
Drawing Number U128_2_M			Henry Audio		Power
			Edition H	Sheet 12 of 13	

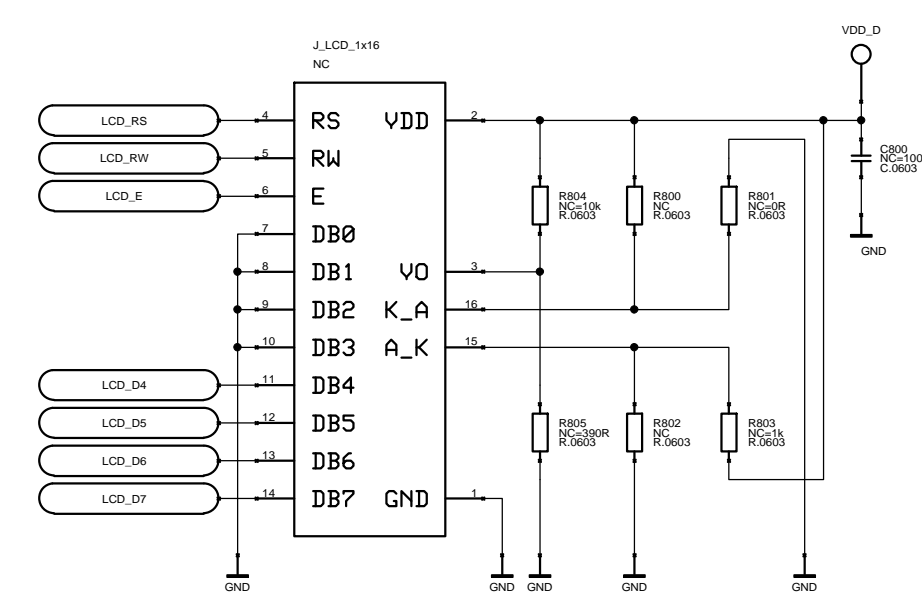
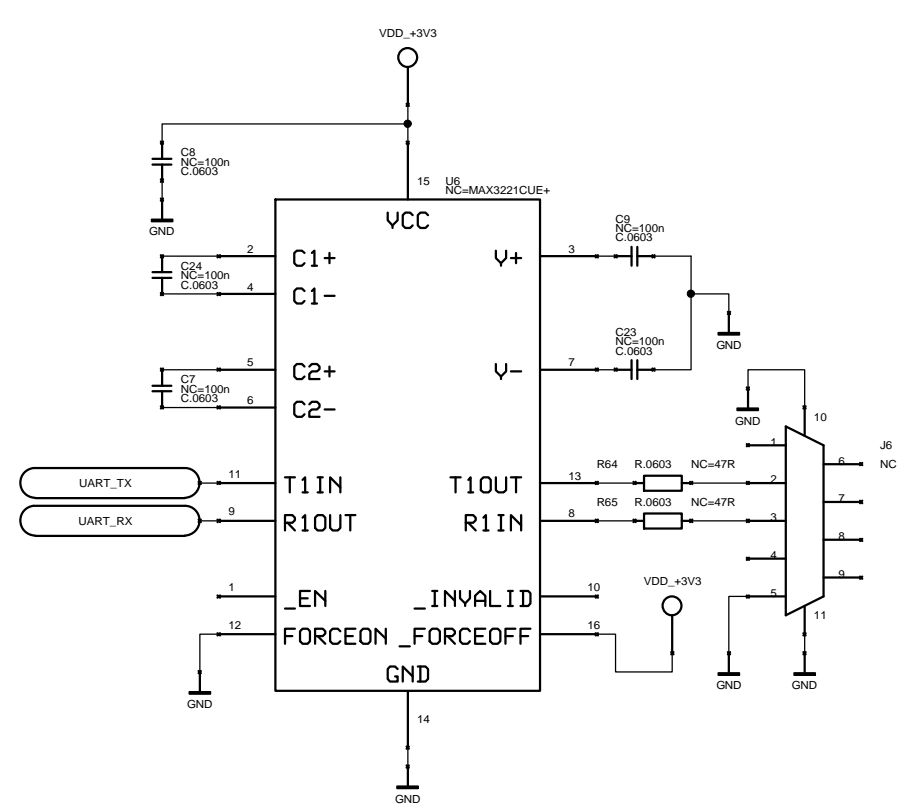
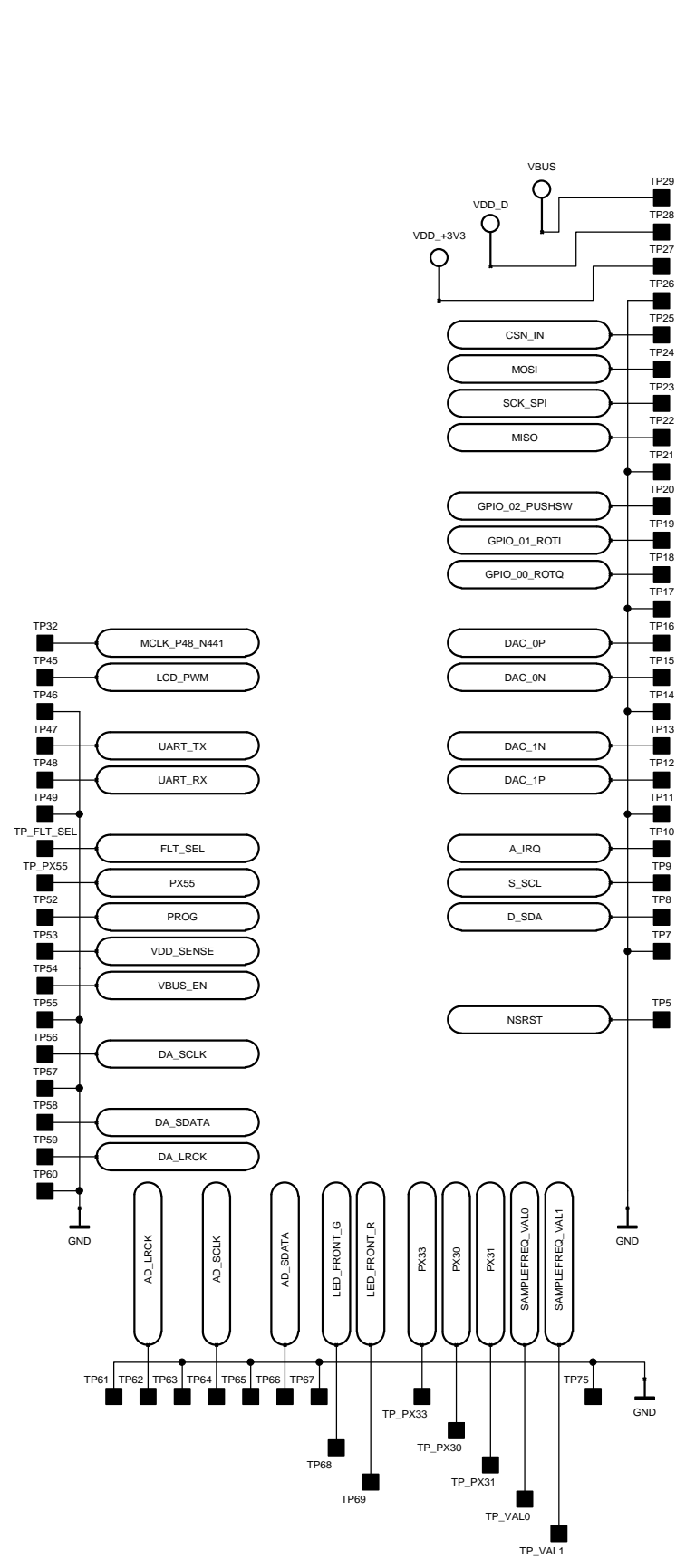

Designed by BSB	Checked by BSB	Approved by - date BSB	Filename U128_2_M	Date 20141012	Scale 1:1
Drawing Number U128_2_M			Henry Audio USB_I2S_MOD_IO		Edition H
					Sheet 13 of 13